

Rubber expansion joint - Type GR-SAE

Universal expansion joint DN 32 – DN 125



Structure type GR-SAE

Universal expansion joint consisting of a rubber bellows and rotatable flanges

Rubber bellows PN 16

- Elastic molded bellows
- High-tensile synthetic fibre reinforcement
- Wire-reinforced self-sealing rubber rim
- Electrical impedance 10^3 to 10^6 Ohm (DIN IEC 93, VDE 0303-30)

Rubber grade*	Colour code	Possible uses
NBR	red/yellow	Oil, hydraulic oil

*Inquire about the resistance of the rubber grade depending on the kind of oil and additives.

Technical design

Max. perm. operating pressure	16 bar*
Max. perm. temperature	+130 °C
Bursting pressure	≥ 48 bar
Vacuum operation	DN 32-50 without vacuum supporting ring, DN 65-125 with vacuum supporting ring

Max. operating pressure to be set 30 % lower for shock loads.

*Please consider a decrease of pressure due to temperature (see technical annex).

Flanges

Version

- Rotatable flanges with stabilizing collar
- Flange drilling for through bolts according to SAE-standard, suitable for socket head cap screw acc. DIN 6912
- Special machined groove for rubber rim

Dimensions

Standard: SAE-standard 3000 psi

Others: PN 16 according to EN 1092

Connection dimensions see technical annex

Materials

Standard: aluminium

Others: 1.0038 (S235JR) etc.

Corrosion protection

Standard: not necessary for aluminium

Others: electrogalvanized, etc.

Applications

- for reducing thermal and mechanical tension in pipes and their system components
- for compensating axial, lateral and angular movement
- for muffling vibration and oscillation at aggregates
- for damping noise transmission at
 - pumps
 - machines
 - fittings
- in hydraulic plants
- in lub oil lines
- mechanical engineering

Accessories

- Vacuum supporting ring
- Internal guide sleeve
- Flame-proof protective cover
- Protective hood
- Protective tube

Certificates

- CE (DGR 97/23/EC)

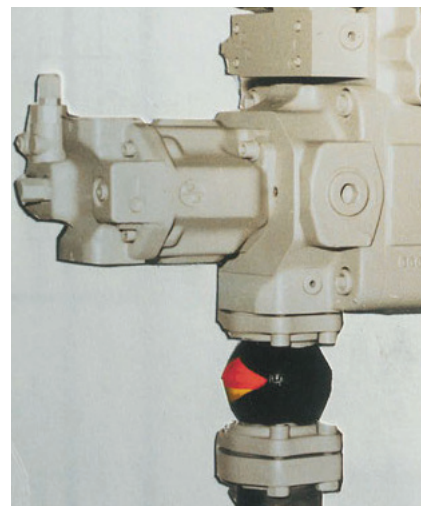

STENFLEX® type GR-SAE in a low-pressure hydraulic system

Dimensions standard program

DN	BL mm	Pressure rate bar	ø di Bellows inner ø mm	ø C Raised face outer ø mm	ø E Raised face inner ø mm	ø W Convolution ø unpressurized mm
32	100	16	22±3	51	30	55
40	130	16	28±3	66	34	81
50	130	16	38±3	76	44	91
65	130	16	48±3	89	57	103
80	130	16	66±3	106	74	118
100	130	16	90±3	135	101	146
125	130	16	118±4	161	130	170

Movement compensation/bellows cross sectional area

DN	Δ ax Axial movement		Δ lat Lateral movement ± mm	Δ ang Angular movement ± ∠ degrees	A* Effective bellows cross sectional area at 16 bar cm²	Weight approx. kg
	Compression - mm	Elongation + mm				
32	20	10	10	25	0	0.4
40	20	10	10	20	38	0.5
50	20	10	10	20	46	0.7
65	20	10	10	15	62	0.8
80	20	10	10	12	76	1.1
100	20	10	10	8	109	1.5
125	20	10	10	8	165	1.8

Please inquire for simultaneous (different) movement.

*Effective bellows cross sectional area is a theoretical value.

Flange dimensions according to SAE-standard

DN	L ₁ mm	L ₂ mm	D ₁ mm	D ₂ mm	b mm	d mm
32	58.7	30.2	79	64	16	11
40	70	35.7	94	75	16	13
50	78	43.0	102	86	16	13
65	89	51.0	116	98	16	13
80	106	62.0	134	120	18	17
100	130	78.0	162	146	18	17
125	152	92.0	190	170	18	17

Note

Please comply with the general technical instructions regarding reaction force, moving force, fixed point load, installation instructions etc.

Subject to technical alterations and deviations resulting from the manufacturing process.

Versions

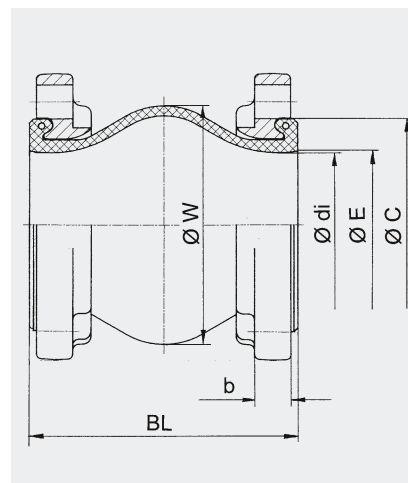

Type GR-SAE
Universal expansion joint

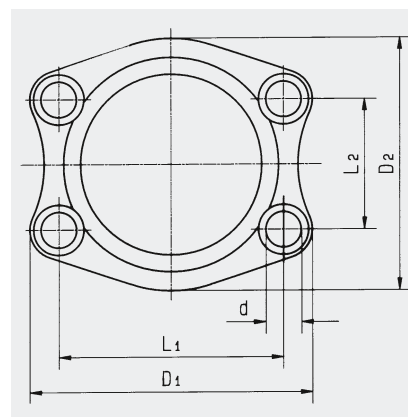

Flange according to SAE-standard