

## Steel expansion joint - Type SA-13

Axial expansion joint DN 15 - DN 1200



### Applications

- for compensating large axial movement
- for installation in
  - long pipe routings
  - industrial applications
  - heating installations
- for gas supply lines

### Special designs

Other sizes (DN), lengths or pressure ratings on request.

### Guide sleeve

#### Materials

Standard: 1.4541

### Accessories

- Protective tube

### Certificates

- CE (DGR 97/23/EG)
- American Bureau of Shipping
- Bureau Veritas
- DVGW (DN 32 - DN 200)
- Germanischer Lloyd
- Lloyd's Register of Shipping

### Versions

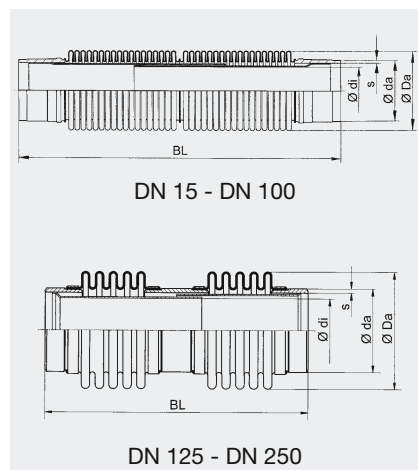

Type SA-13

### Structure type SA-13

- Vacuum-proof axial expansion joint consisting of two stainless steel bellows (DN 125 - DN 1200 with connecting pipe) and welded pipe ends (welding ends)
- Guide sleeves to stabilize the expansion joint
- Guide sleeves do not supersede pipe guide bearings

### Steel bellows PN 10 / PN 16

- Multiple convolution bellows in various stainless steel grades
- One ply or multi-ply structure

Material grade *	Material No. as per DIN EN	Temperature**	Possible uses
Stainless steel	1.4541	-196 °C	Low temperature, acids, lyes, gases, fertilizers
	1.4404, 1.4571	up to +550 °C +550 °C	

\* Check or inquire about the resistance of material grades to temperature and medium.

\*\* Check or inquire about reduction in pressure by temperature.

### Welding ends/connecting pipe

#### Version

- Welded pipe ends and connecting pipe

#### Dimensions

Standard: see tables

Others: DIN EN, ANSI, BS etc.

#### Materials

Standard: 1.0345 (P235GH), 1.0038 (S235JR)

Others: stainless steel, etc.

#### corrosion protection

Standard: anti-corrosion primed

Others: special varnish, etc.

### Note

Please comply with the general technical instructions regarding reaction force, moving force, fixed point load, installation instructions, etc.

Subject to technical alterations and deviations resulting from the manufacturing process.

**Pressure rate**    **PN 10**    **standard program**

DN	BL	$\Delta a_{x_{tot}}$ Axial movement	$C_{ax}$ Axial spring rate	A* Effective bellows cross sectional area	$\phi D_a$ Bellows outer $\phi$ mm	$\phi d_i$ Guide sleeve inner $\phi$ mm	$\phi d_a \times s$ Pipe connection	Weight
	mm	mm	N/mm	cm <sup>2</sup>	mm	mm	mm	approx. kg
15	260	48	25	7	38	14	21.3x2.0	0.7
20	260	48	25	7	38	18	26.9x2.3	0.7
25	270	40	25	16	54	24	33.7x2.6	1.0
32	270	40	25	16	54	32	42.4x2.9	1.0
40	300	52	34	25	66	37	48.3x2.6	1.1
50	320	68	44	36	79	47	60.3x2.9	1.9
65	357	72	51	54	96	60	76.1x2.9	2.8
80	358	80	40	78	116	74	88.9x3.2	3.6
100	386	80	46	115	136	95	114.3x4.0	4.4
125	475	100	40	173	168	116	139.7x4.0	8.1
150	535	100	78	243	196	145	168.3x4.5	11.0
200	545	76	119	422	253	193	219.1x6.3	17.1
250	545	76	312	620	302	246	273.0x6.3	21.4
300	730	140	91	993	387	291	323.9x8.0	64.0
350	730	138	99	1180	419	323	355.6x8.0	71.0
400	730	136	113	1511	470	373	406.8x8.0	81.0
450	730	134	126	1893	521	424	457.0x8.0	92.0
500	730	132	140	2287	571	475	508.0x8.0	103.0
600	730	132	167	3233	673	577	610.0x8.0	124.0
700	730	130	194	4343	775	678	711.0x8.0	146.0
800	730	128	221	5603	876	780	813.0x8.0	167.0
900	730	128	247	7023	977	877	914.0x10.0	189.0
1000	730	128	274	8619	1079	979	1016.0x10.0	210.0
1200	730	128	327	12303	1283	1182	1219.0x10.0	253.0

**Pressure rate**    **PN 16**    **standard program**

DN	BL	$\Delta a_{x_{tot}}$ Axial movement	$C_{ax}$ Axial spring rate	A* Effective bellows cross sectional area	$\phi D_a$ Bellows outer $\phi$ mm	$\phi d_i$ Guide sleeve inner $\phi$ mm	$\phi d_a \times s$ Pipe connection	Weight
	mm	mm	N/mm	cm <sup>2</sup>	mm	mm	mm	approx. kg
15	260	48	25	7	38	14	21.3x2.0	0.7
20	260	48	25	7	38	18	26.9x2.3	0.7
25	270	40	25	16	54	24	33.7x2.6	1.0
32	270	40	25	16	54	32	42.4x2.9	1.0
40	300	52	34	25	66	37	48.3x2.6	1.1
50	320	68	44	36	79	47	60.3x2.9	1.9
65	357	72	51	54	96	60	76.1x2.9	2.8
80	358	80	40	78	116	74	88.9x3.2	3.6
100	386	80	46	115	136	95	114.3x4.0	4.4
125	475	100	40	173	168	116	139.7x4.0	8.1
150	535	100	78	243	196	145	168.3x4.5	11.0
200	545	140	119	422	253	193	219.1x6.3	17.1
250	545	104	312	620	302	246	273.0x6.3	21.4

Table values refer to +20 °C, bellows material 1.4541, 1000 cycles. Max. allowable pressure pulsation of 1.0 bar (brief periods).

Please inquire for deviating values.

\*Effective bellows cross sectional area is a theoretical value.

ООО «ТИ-СИСТЕМС» ИНЖИНИРИНГ И ПОСТАВКА ТЕХНОЛОГИЧЕСКОГО ОБОРУДОВАНИЯ

Интернет: [www.tisys.ru](http://www.tisys.ru) [www.tisys.kz](http://www.tisys.kz) [www.tisys.by](http://www.tisys.by) [www.tesec.ru](http://www.tesec.ru) [www.tи-системс.рф](http://www.tи-системс.рф)

Телефоны: +7 (495) 7774788, 7489626, 5007155, 54 Эл. почта: [info@tisys.ru](mailto:info@tisys.ru) [info@tisys.kz](mailto:info@tisys.kz) [info@tisys.by](mailto:info@tisys.by)